

Versatile Scalable Intelligent Inserter

The Sensible Technologies ST-LX Intelligent Inserting System is our high speed document inserting solution. This cutting edge solution is excellent for high page count processing.

••• System Features

- Inserter Cycle Speeds up to 11,000 cycle per hour
- Feeder Speeds up to 40,000 plus documents per hour
- Sequential Start-up and Shut Down
- Multi Page Accumulation
- Station Selection on all pockets
- Heavy Duty Folder with urethane rollers
- 1D (3 of 9) or 2D (Data Matrix) Barcode Reading
- Non Streak Accumulator

••• Options

- OMR Reading
- Read & Print
- Station to Station Matching
- Feeder to Feeder Matching

- **Designed for maximum productivity, 24-hour, seven days a week mail production**
- **High folding capacity, up to eight pages for a letter fold, fifteen pages for a half fold**
- **Advanced touch screen for easy operator interface**
- **Up to 40,000 plus documents per hour**
- **Easily interfaces with conventional inserters**
- **Unlimited intelligent station selection**
- **Sequential start-up and shut down**
- **Computerized weighing**

Luxe Feeder / Folder Key Features

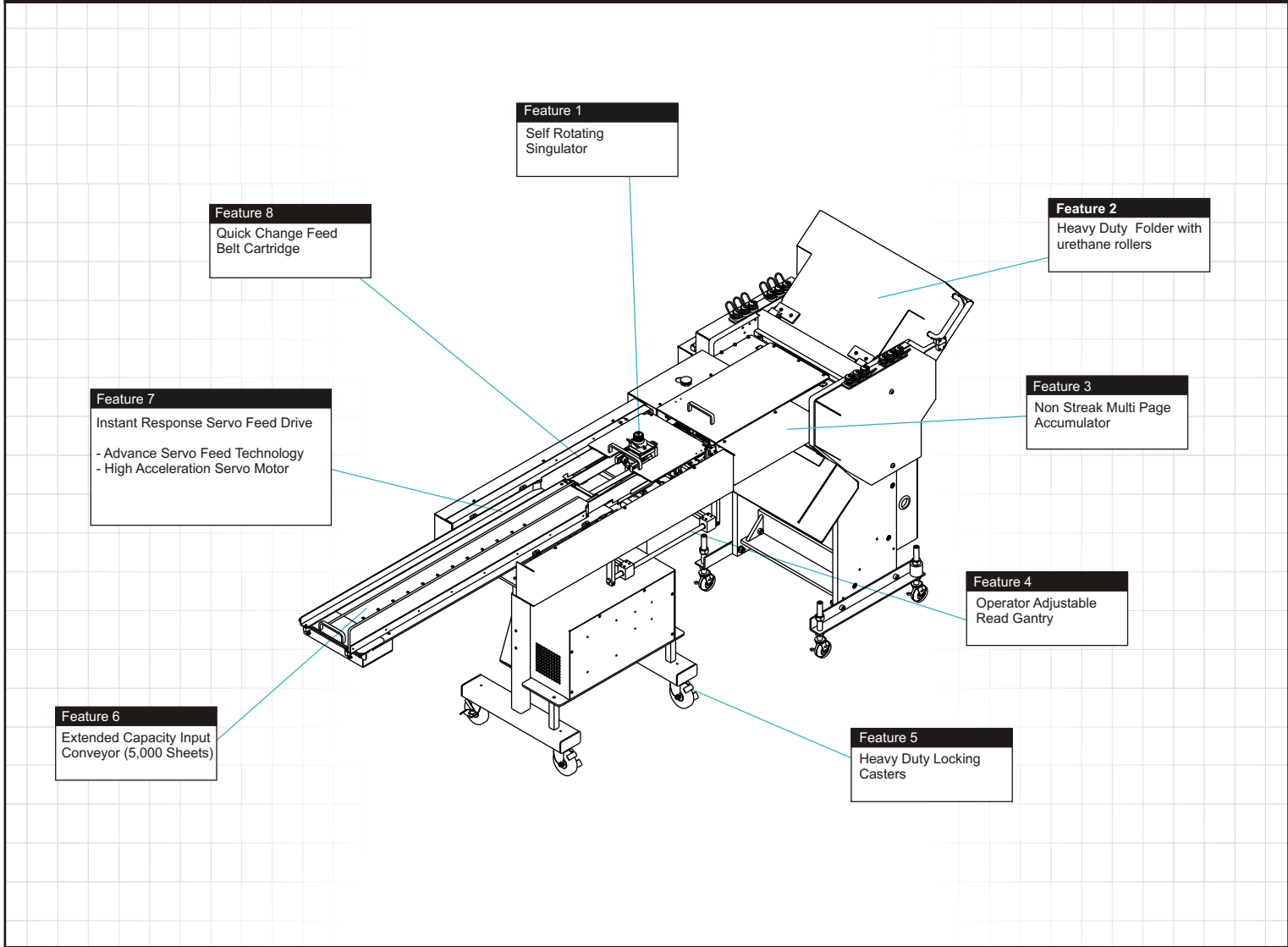

CutSheet Luxe System Footprint

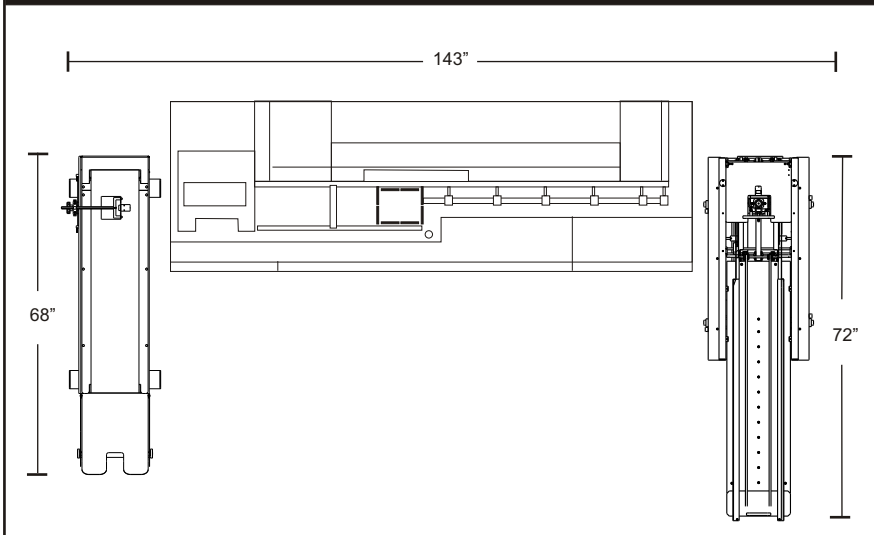

For more information on specifications please visit: sensibletech.com

Technical Specifications

Minimum Product Size	8.5" W x 11"L / A4
Maximum Product Size	8.5" W x 14"L
Paper Weight	Min: 20# Bond / Max: 100# Cover Call for more information
Paper Capacity	2,000 / optional: 5,000
Fold Types	"C", "Z", "V", and Double "V"
Speed	Up to 40,000 plus documents per hour
Power Source	240 Volts, Single Phase, 30 amp 4-wire
Read Systems	OMR Industry Standard Barcodes: 3 of 9, 128 and 2 of 5 Interleaved 2-D Barcode - DataMatrix;